

SBC-6104/ 6106/ 6111 12V-12V In-Car Charger

Operation manual

Keep this manual in a safe place for quick reference at all times.

*This manual contains important safety and operation instructions for correct use of the battery charger.
Read through the manual and pay special attention to the markings and labels of the charger,
battery and equipment connected to the battery system.*

Pay special attention to these two types of notices used in this manual.



Failure to heed this warning may cause injury to persons and damage to Equipment.



***Failure to observe this warning may result in damage to equipment
and improper functioning of the Charger.***

WARNING:

- *The charger is **not** designed for any life saving application.*
- *The charger is designed for in-door use. Protect the charger from ingress of water.*
- *This charger is made to charge **only** properly sized lead acid batteries and LiFePO₄ (LFP).*
- *Don't recharging non-rechargeable batteries.*
- *Charging other types of battery or under-sized lead acid batteries may cause fire or explosion.*
- *Install the charger in accordance with all local codes.*
- *Do not use the charger if it has been dropped or damaged.*
- *Never attempt to charge a frozen LEAD BASED battery.*
- *Never attempt to charge LiFePO₄ battery below minus 5°C.*
- *Never attempt to charge LiFePO₄ battery without build-in BMS (Battery Management System)*
- *Never attempt to charge a damaged battery.*
- *Wear protective goggles and turn your face away when connecting or disconnecting the battery.*
- *Never place the charger on top of a battery.*
- *Never smoke, use an open flame, or create sparks near battery or charger during normal charging operation as batteries may give out explosive gas.*
- *Do not charge batteries in an enclosure (box- in) due to possible explosion of entrapped explosive gas.*
- *If the charger does not work properly or if it has been damaged, unplug all DC connections.*

Copy Right

All rights reserved.

No part of this publication may be reproduced, or transmitted in any form or by any means without the written permission from Manson Engineering Industrial Ltd.

Changes in the manual.

Manson Engineering Industrial Ltd. has the right to update and change the content of this manual without any prior notice and obligation.

Disclaimer

Exclusions for documentation, Indemnity and Product application.

Manson Engineering Industrial Ltd. (Manson)

- 1) Assumes no warranty to the accuracy, suitability of technical information given in the user manuals or other documentation.*
- 2) Undertakes no responsibility or liability of losses, damages and related expenses whether specific, direct, indirect consequential or accidental which might result from the use of information given in this manual.*
- 3) Shall not be liable to anyone for any special, collateral, incidental or consequential damages in connection with or from the use of these Manson products. The sole and exclusive liability to Manson, regardless of the form of action shall not exceed the purchase price of the Manson product.*

Introduction

Optimal Efficiency 92% with Digital Control

The high power conversion efficiency allows quiet and cooling running of charger and can provide continuous full load operation at 40°C ambient temperature

Designed to cover old and new types of car alternators

This charger is designed to address the issues of wide swing of output voltages from the smart alternator, braking regenerative EURO5/6 vehicles in fully charging the house battery. They are also suitable for use with distance house battery. The charger Booster provides fast safe charging profiles for 4 types of lead based and 2 types of Lithium (LiFePO4) batteries.

Multistage Charging

This is a select (battery type) and forget charger designed for fast accurate and safe recharge of your house battery banks. The (digital control) smart multistage charging enables the charger to be connected permanently to your battery banks without the worry of over charging or drying out the electrolyte.

Lead Acid Based Battery

3 Stage Bulk, Absorption & Float charging profile for 4 types of lead acid based battery with maximum constant charging current at the Bulk Stage and a Constant Voltage with decreasing charging current at the Absorption Stage and a reduced voltage Float Charge for maintenance when battery is full.

Lithium (LiFePO4) Battery

Defaulted 3 Stage charging same as Lead Acid battery however Float charge can be disabled by APP¹ and then stop charging at the end of Absorption Stage. (Remark 1: Only can be applied by advanced App)

Three Trigger Charge Control

- Ignition Control : Charger starts charging only when ignition is on and stops charging when Ignition is off.
This is the recommended control as it is safer and allows for large input voltage range.
- Input Voltage Control : This is for non-intelligent or older type alternators with sufficient high & uniform voltage.
Charging is cut off easily due to high threshold voltage to protect the starting battery.
- Vibration Sensor Control : Charger starts charging when repeated vibrations are detected and stops charging when no vibration is detected for over 2 minutes. The built-in vibration sensor makes it possible to use the charger by just connecting to the starter terminal without touching the car's electrical/electronic wiring thus avoiding any possible excuse for revoking the car's warranty.

Reverse Charging

Only for 12V Input (starter) battery this charger has reverse current charging at around 17A for SBC-6104, 20A for SBC-6106 and 40A for SBC-6111 under the following conditions. And this feature can be selected to ON or OFF by Select Button.

For Lead & AGM battery type:

Output terminal voltage (auxiliary battery) must be is higher than 13.2V and input terminal (starter battery) is lower than 13.2V. The charger will switch to reverse charging mode only when both ignition control and vibration control are dormant and is not being used.

For Lithium battery type:

Output terminal voltage (auxiliary battery) must be is higher than 13.5V and input terminal (starter battery) is lower than 13.5V. The charger will switch to reverse charging mode only when both ignition control and vibration control are dormant and is not being used.

Manual Override Feature

When Starter battery voltage is higher than 5.5V and Auxiliary battery voltage is higher than 11V, press the Select Button 4 times can be manual enabled reverse charge with charging voltage 13.5V for a short period or time to let the Auxiliary battery to charge back the Starter battery in emergency.

Bluetooth Connectivity

Only for models with preinstalled Bluetooth feature.

Available APP via Android or IOS phone:

Output voltage, Current, Charging status, Battery type select are displayed on the phone.

Input Battery low voltage power derating

When the input battery voltage is lower than 13.5V at Ignition mode or vibration mode, the output charging current will de-rate according to the input battery voltage automatically so to let the charger always working at the best performance even input battery under low voltage condition.

Features

- Power conversion efficiency > 92%.
- 6 selective charging profiles suitable for charging for the most lead acid & Lithium (LiFePO4) batteries.
- Supplied with a remote Battery temperature sensor to ensure precise and safe charging in large temperature variation.
- 3 types of operation control to choose for specific situation.
- Alarm signal (fault or not charging) available to integrate with your system.
- Thermostatically speed control Fan.

Protections

- Self Recoverable Input Under Voltage Protection.
- Self Recoverable Input Over Voltage Protection.
- Self Recoverable Output Under Voltage Protection.
- Self Recoverable Output Over Voltage Protection.
- Self Recoverable Over Current protection.
- Self Recoverable Output Short Circuit Protection.
- Self Recoverable Charger Over Temperature Protection.
- **WARNING:**
No input and output battery reverse polarity protection. Reverse polarity will damage the charger.

Supplied Accessories

- Remote battery temperature sensor.

Installation Procedure



Do NOT install this unit in the **vehicle engine bay**.

This is a fan cooled electronic device not for use in high temperature, corrosive and dusty environment which will drastically shortens the life and performance of the charger.



This charger is designed only for internal mounting and away from direct sunlight, heat and rain. Allow at least 80mm of space at both ends for ventilation.

We recommend wiring by a qualified automobile electrician to ensure local safety and on-board standard are followed

1. To provide the best cooling effect, mount the unit in vertical position with the terminal end facing downwards due to the top front exhaust design.
2. First install the charger as close to the house battery as possible via a fuse.
3. Check the LED indicators by a few presses on the Select Button.
4. Before connect input to DC Alternator, check on type of alternator of car, for new car with smart alternator select ether Vibration Sensor Mode or Ignition Feed Mode.
5. Do not charge Lithium (LiFePO4) battery without built in Battery Management System.
6. Do not charge Lithium (LiFePO4) battery below 0°C.& discharge below minus 5°C. Check with battery maker.

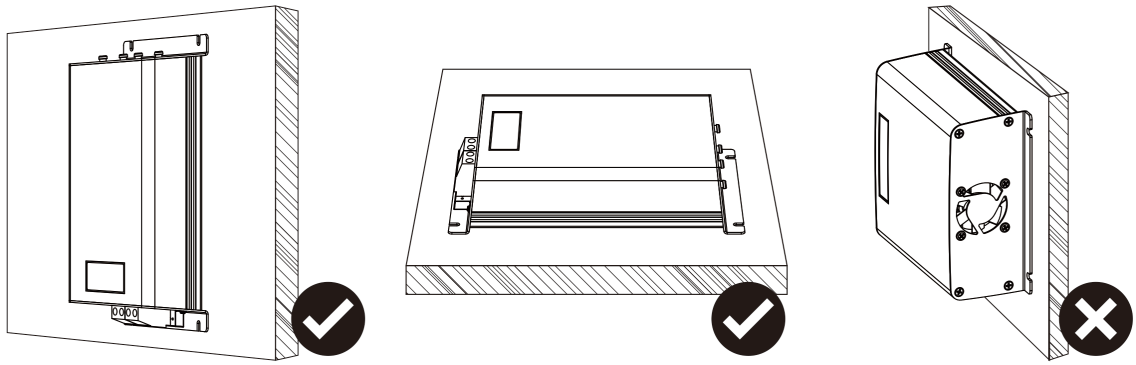

Fig. 1: correct installation direction

Indicators and Controls

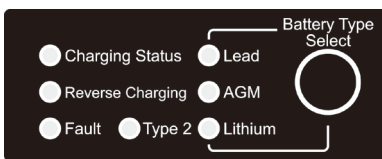

Fig. 2: 7 LED display

Select Button

The Select Button is for selection of battery, deactivate Ignition Control Mode, turn ON/ OFF the reverse charging feature and Manual Override feature.

- Long press the Select Button for 5 seconds for battery selection.
- Long press the Select Button for 15 seconds to deactivate Ignition Control Mode.
- Long press the Select Button for 20 seconds to turn ON/ OFF the reverse charging feature.
- Press the Select Button 4 times to activate the Manual Override feature which can force the reverse charging.

Charging Status

Charging Status LED for LEAD ACID Battery - 3 Stages

Charging status LED	Charging stage
Fast flashes	Bulk charge
Slow flashes	Absorption
Solid	Float

Charging Status LED for Lithium (LiFePO4) Battery - 3 Stages (Default)

Charging status LED	Charging stage
Fast flashes	Bulk charge
Slow flashes	Absorption
Solid	Float (can be disabled by APP ¹) (Remark 1: Only can be applied by advanced App)

Reverse Charging

Reverse Charging LED: This LED ON when Reverse Charging.

The reverse charging feature is defaulted as ON. It can be changed by the following procedures.

1. Press and hold the Select Button for about 20 seconds until the 3 LED battery types all become solid from flashing and then release the Select Button.
2. Press the Select Button to toggle reverse charging feature to be ON (Reverse Charging LED ON) or OFF (Reverse Charging LED OFF).
3. The selection will be confirmed automatically after 5 seconds.

Battery Type Selection

1. Press and hold the only Select Button for about 5 seconds until the LED flashes.
2. Light quick presses will move the LED from Lead--> AGM--> Lithium--> Type 2+Lead--> Type 2+AGM--> Type 2+Lithium--> Lead.
3. Stop at the chosen battery type and wait till LED stops flashing to confirm your selection.

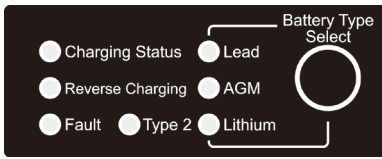

Connections

After both input and output are connected, the charger will have output after 10 Sec.

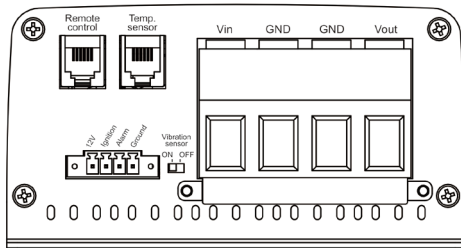

SBC-6111

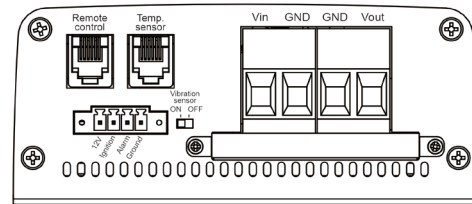

SBC-6104/ 6106

Fig 3.: Terminals

Vin:	Input positive (Ve+) terminal.
Vout:	Output positive (Ve+) terminal.
GND:	Ground (Ve-) terminal for input and output. It is common ground for input and output.
Temp sensor:	Temperature sensor connection port. (Temp sensor is calibrated at 25°C to compensate the charging voltage by -20mV/ °C)
12V:	Positive 12V 50mA for ignition control use.
Ignition:	Ignition control pin, for connecting to terminal 15 of car.
Alarm:	Alarm output pin. 12V 100mA for external alarm.
Ground:	Ground pin for alarm.
Vibration sensor:	Switch on/off of vibration sensor.

Charger Control Modes

There are 3 automatic charge modes plus one manual ON-OFF to switch on and off the charger to give the optimal charging current to the auxiliary battery.

Automatic Ignition Control Mode

It synchronizes ON/OFF of the DC-DC charger with the car's ignition.

This mode requires connection to the car's Ignition Signal **Terminal 15** electrical circuit which gives out a positive DC Voltage from the car's electrical wiring when the ignition is turned on. The ignition control will set to ON once the **Ignition Pin** is applied with 9-16V voltage. The charging operation stops when Ignition is off & engine stops running.

This mode is recommended for all alternator types including Europe 6, 6+plus with start/ stop energy saving.

Manual Control

You can wire a contact switch with one end to the **Ignition Pin** and the other to **12V Pin**. Shorting both pins will turn on the charger, disconnect will turn off the charger.

Vibration Sensor Control Mode

Switch ON the vibration sensor to enable build-in vibration sensor

The built in vibration sensor with special software control turns on the charging when trains of vibrations are detected. Installation is simple and quick and without touching the car's electrical system for the sensor to work.

Over-riding Ignition Feed by Vibration Sensor

Built-in vibration sensor when enabled dominates the control of output and over-rides all other Modes including the Ignition Feed. That is only vibration can make the charger start charging with output ON.

CAUTION:

DO NOT USE VIBRATION SENSOR CONTROL WHEN CAR IS ON FERRY, TRAIN OR OTHER TRANSPORT PLATFORMS WITH REGULAR VIBRATIONS & SHOCKS.

REMARK

Once the Vibration Sensor Mode is disabled, the charger will return to the last selected mode. If you are not sure about your last selected mode, you can set the charger to your desired mode.

Cancel Ignition Control

- i) Take out connection to the **Ignition pin**.
- ii) Press and hold the select button for around 15 seconds until the 3 LED battery type flash at the same time.
- iii) Release the select button and charger changes to Input Voltage Control.

Input Voltage Control Mode

This mode requires increased voltage (>13.5V +/- 0.2V) of the starter battery which is only possible with short thick cable connection and old type alternator with sufficiently high and stable charging voltage. This Control Mode is not suitable for modern cars due to wide voltage range such as Euro 5/6. Cancel the Ignition Control first in order to get into this mode.

Summary of 3 Control Modes Operation voltages

CHARGE MODE	12V CAR	
	CHARGE ON	CHARGE OFF
Vibration Sensor Mode when sensor is triggered by vibration from car	12.0-16.0V +/- 0.2V	≤11.0V +/- 0.2V
Ignition Feed – Automatic Mode connect to Ignition switch when Ignition is on	12.0-16.0V +/- 0.2V	≤11.0V +/- 0.2V
Factory Preset Mode Vibration Sensor & Ignition Feed Inactive	13.5-16.0V +/- 0.2V	≤12.8V +/- 0.2V

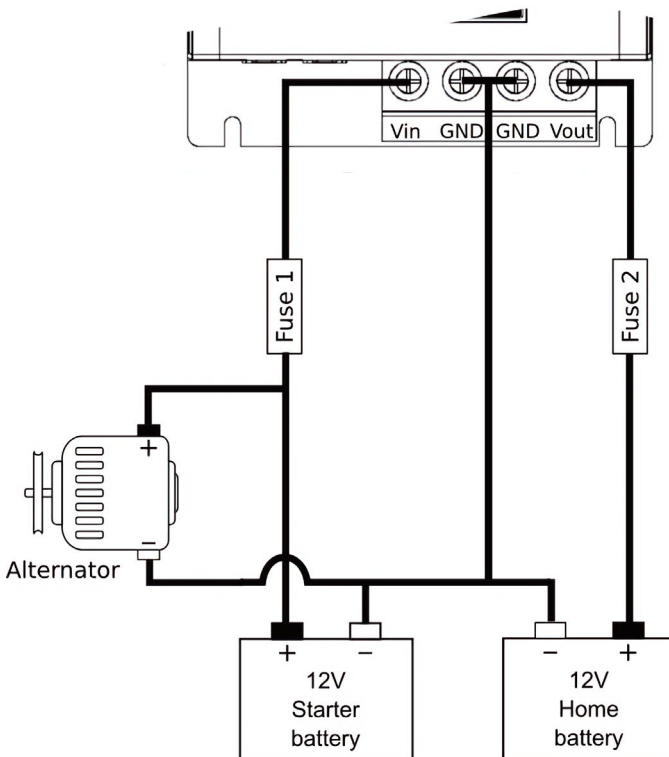

Input and output fuse

Please use the following value for recommended external input (FUSE 1) and output (FUSE 2) fuses

Recommended FUSE rating

	SBC-6104	SBC-6106	SBC-6111
FUSE 1	50A	80A	125A
FUSE 2	50A	80A	125A

Fig 4.: Connection diagram

Specification

Models	SBC-6104	SBC-6106	SBC-6111
Rated Output power	38A at 13.8VDC	60A at 13.8VDC	110A at 13.8VDC
Efficiency	≥92%		
Input			
DC Input Voltage Range	11 – 16VDC		
No load input current	<20mA		
Output (Charge) Voltage			
Battery Type			
Lead	Absorption 14.4V	Float 13.3V	
Lead 2	Absorption 14.6V	Float 13.5V	
AGM	Absorption 14.2V	Float 13.1V	
AGM 2	Absorption 14.7V	Float 13.6V	
Lithium	Absorption 14.4V	Float 13.8V	
Lithium 2	Absorption 14.6V	Float 13.6V	
Reverse Charge Voltage	13.5V		
Reverse Charge Current	17A	20A	40A
Additional output			
Alarm Output	12V 100mA		
12V signal for ignition use	12V 50mA		
Recommended Cable Size			
Cable Length	Recommended SAE		
1 – 3 Meters	8AWG	6AWG	4AWG
4 – 6 Meters	6AWG	4AWG	2AWG
Recommended External Fuse rating			
Input FUSE	50A	80A	125A
Output FUSE	50A	80A	125A
Operating Mode			
Vibration Sensor Mode	Charge ON: 12.0-16.0V +/- 0.2V Charge OFF: ≤11.0V +/-0.2V		
Ignition Feed – Automatic Mode	Charge ON: 12.0-16.0V +/- 0.2V Charge OFF: ≤11.0V +/- 0.2V		
Factory Preset Mode	Charge ON: 13.5-16.0V +/- 0.2V Charge OFF: ≤12.8V +/- 0.2V		
Accessories			
Accessories	Battery Temperature Sensor (Temp. sensor is calibrated at 25°C to compensate the charging voltage by -20mV/ °C)		
Protection			
Protection	Input under voltage protection Input over voltage protection Output over voltage protection Over current protection Charger over temperature protection		
Approval	CE		
Cooling Method	Thermostatically Controlled Variable Low Speed Fan		
Dimension (LxWxH)	160x130x56mm 6.5x5.1x2.2 inch	200x130x56mm 7.9x5.1x2.2 inch	210x130x73mm 8.5x5.1x2.9 inch
Weight	0.8kg 1.8lbs	1.0kg 2.2lbs	1.8kg 4.0lbs
Operation Temperature	-10° to +50°C (Can give full output at +40°C)		